

Data sheet

Valve Body RA 15/6TB for conventional two pipe systems

Application

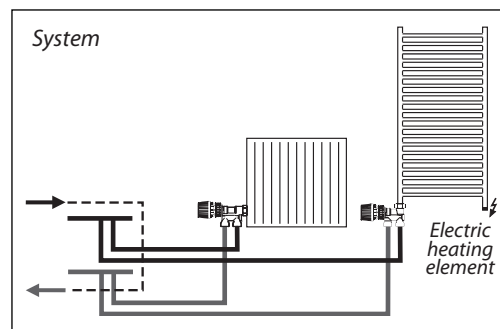
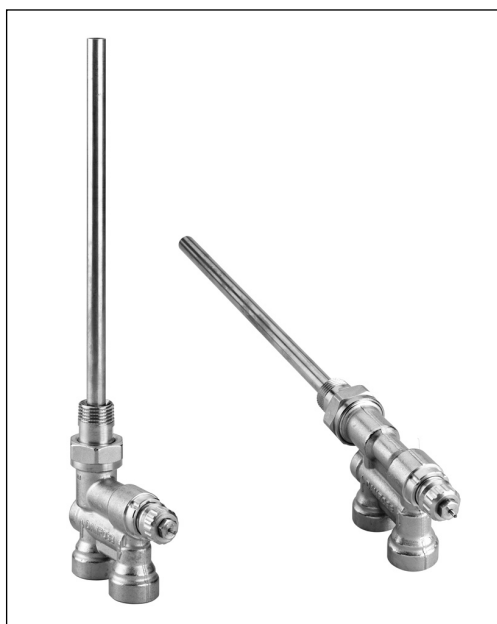

The RA 15/6TB valve body fits the RA 2000 thermostats and the TWA thermal actuators.

The RA 15/6TB is a special lance valve body which allows the radiator to be connected at one point only, at the side of the radiator or underneath it as required.

RA 15/6TB is designed for conventional two-pipe systems with pumped circulation.

The valve body has fixed k_v -values.

Efficient mounting is enabled by a range of compression fittings for steel, copper, PEX and AluPEX pipes.

To prevent scale and corrosion, the composition of the heating water should comply with VDI (Verein Deutscher Ingenieure) [German Engineering Association] guideline 2035.

Depending on the type of radiator, baffle plates or special connectors which match the radiator may be required in some circumstances. Please note that when a bypass valve is fitted, not all the radiators will provide the performance quoted in their catalogue, and variations in performance may arise where different radiators are combined. In this case, please ask your radiator manufacturer for detailed information.

Ordering and data

Type	Code no.	Connection ISO 7-1		k_v -value ¹⁾ m ³ /h at Xp				k_{vs}	Max. pressure			Max. temp.
		System	Radiator	0.5	1.0	1.5	2.0		Work. ²⁾	Diff.	Test	
RA 15/6 TB, floor conn.	013G3210	Rp 1/2	R 1/2	0.29	0.51	0.70	0.82	1.00	10 bar	0.6 bar	16 bar	120 °C
RA 15/6 TB, wall conn.	013G3215											

¹⁾ The k_v -value indicates the water flow (Q) in m³/h at a pressure drop (Δp) across the valve of 1 bar; $k_v = Q: \sqrt{\Delta p}$. The k_v -value is stated according to EN 215, at XP = 2K i.e. the valve is closed at 2°C higher room temperature. At lower settings the XP value is reduced to 0.5K. The k_{vs} -value states the flow Q at a maximum lift, i.e. at fully open valve.

²⁾ Working pressure = static + differential pressure. The maximum differential pressure specified is the maximum pressure at which the valves give satisfactory regulation. As with any device which imposes a pressure drop in the system, noise may occur under certain flow/pressure conditions. To ensure quiet operation, maximum pressure drop should not exceed 30 to 35 kPa. The differential pressure can be reduced by the use of the Danfoss differential pressure regulators types ASV-P.

Spare parts

Product	Units per package	Code no.
Gland seal	10 pcs.	013G0290

The gland seal can be replaced quickly without draining down the system.

Capacity

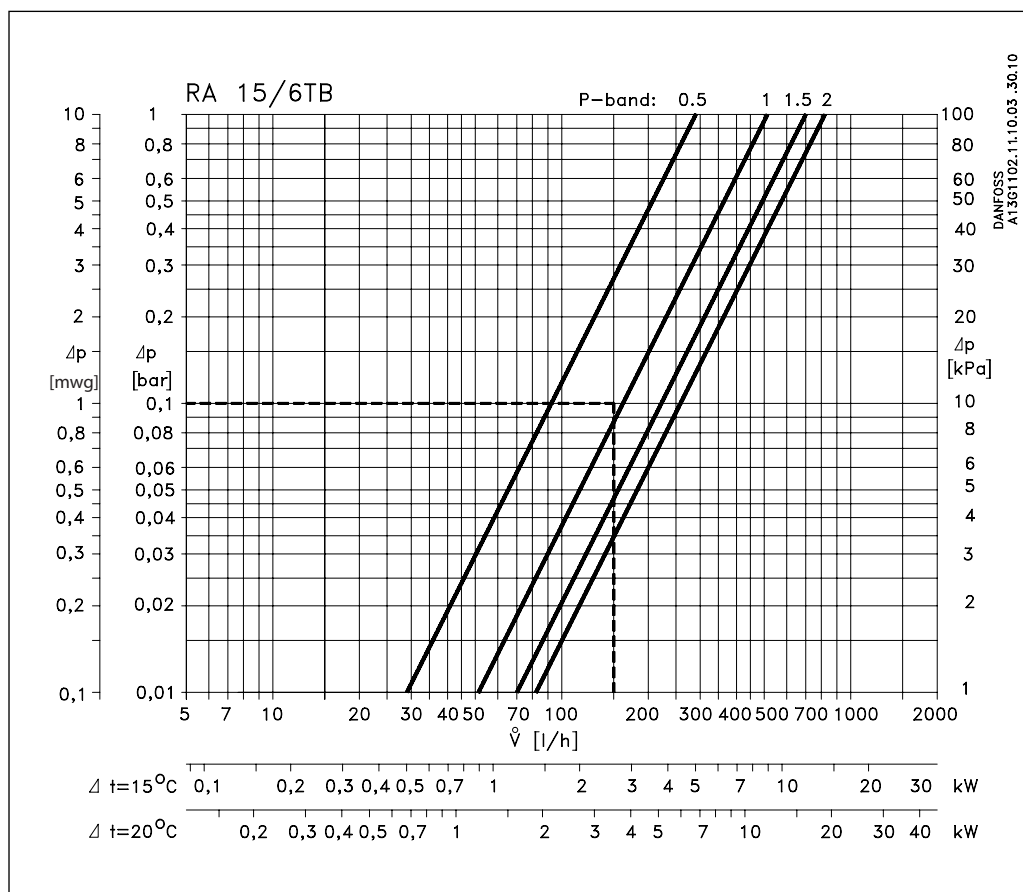

Construction

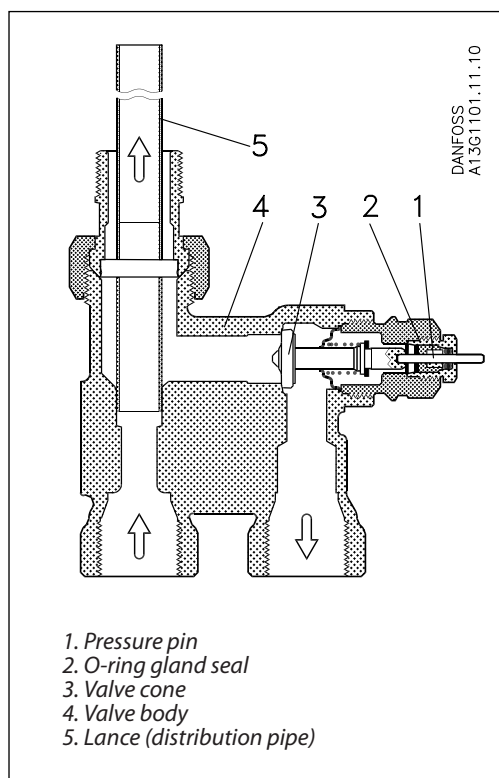

Materials in contact with water

Pipe supporting bush	PP
O-ring	EPDM
Valve cone	NBR
Pressure pin	Chrome steel
Lock washer	Tin alloy
Valve body and other metal parts	Ms 58 brass

Valve bodies are nickel plated.

Mounting

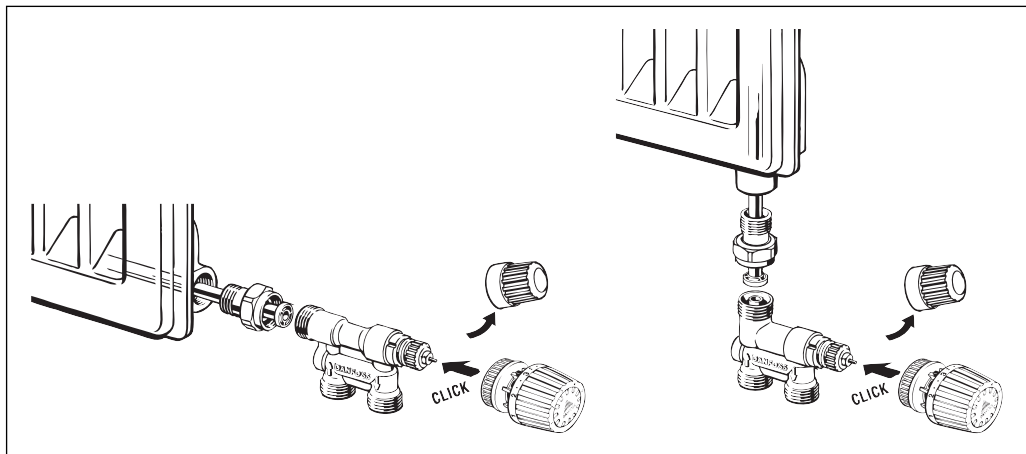

Dimensions

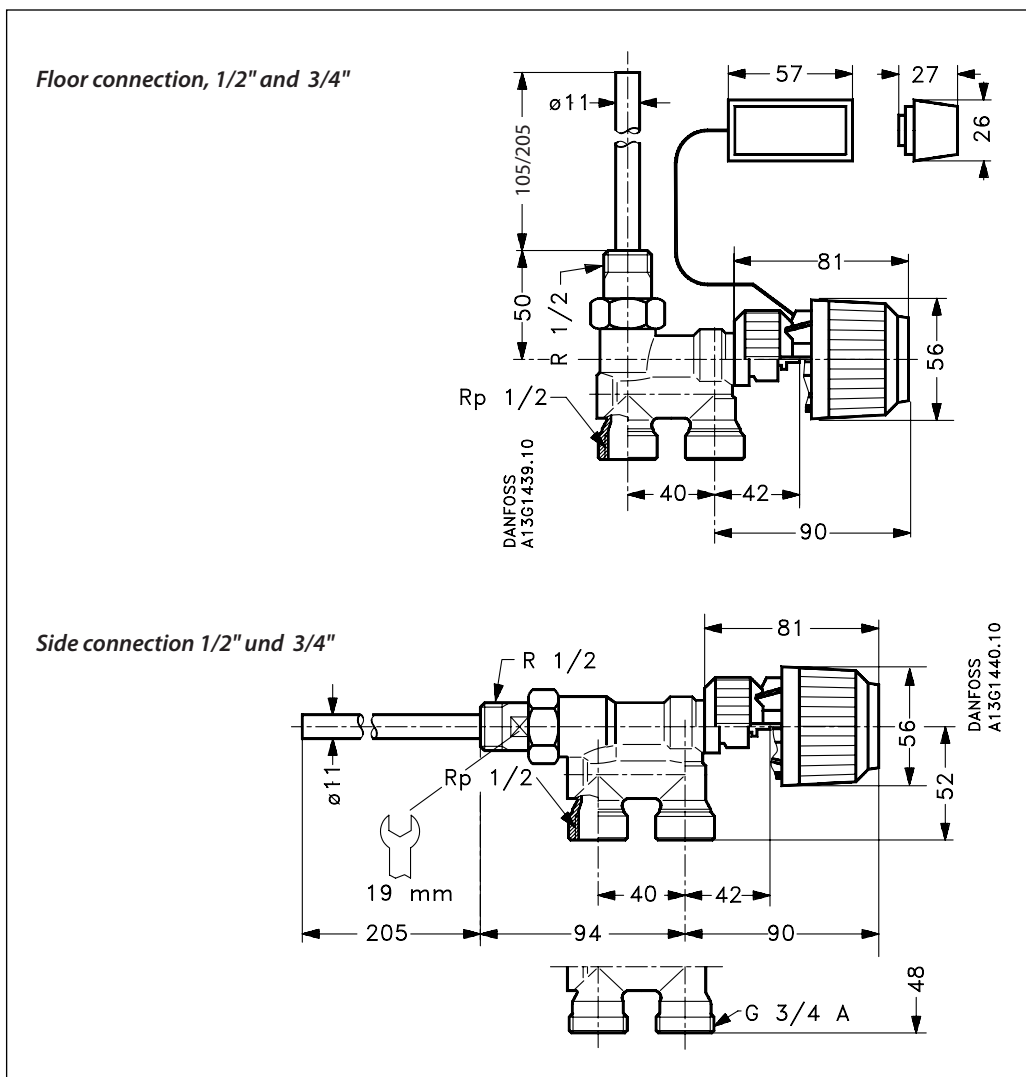

Danfoss can accept no responsibility for possible errors in catalogues, brochures and other printed material. Danfoss reserves the right to alter its products without notice. This also applies to products already on order provided that such alterations can be made without subsequential changes being necessary in specifications already agreed. All trademarks in this material are property of the respective companies. Danfoss and the Danfoss logotype are trademarks of Danfoss A/S. All rights reserved.

