

Data sheet

Flow directors for tube segment radiators - to be used with integrated valve 013G1382

Application



The Danfoss flow directors 013G1525/013G1557 are designed to be used with Danfoss integrated valve type 013G1382 for incorporation into tube segment radiators.

Tube segment radiators are constructed by a series of elements, which are welded together. The first segment is used as inlet pipe, while return is through the bottom of the second segment.

When integrated valves are used in tube segment radiators, the water flow needs to be directed correctly through the valve to avoid noise problems. This is made with the Danfoss flow director.

Code nos. and technical data

Flow director

Flow director type	Connection radiator	Connection integr. valve	Max. water temperature	Code no.
For tube segment radiators	1" RH thread	½"	120 °C	013G1525
For tube segment radiators	1" LH thread	½"	120 °C	013G1557

Integrated valve for flow director

Valve type	Differential pressure ¹⁾		Test pressure	Work. pressure	Max. water temp.	Code no.
	Recom.	Technical				
For Danfoss RA type sensors	0.05-0.2 bar	0.6 bar	16 bar	10 bar	120 °C	013G1382

¹⁾ The technical differential pressure indicates the upper limit for a proper valve function. In most two-pipe systems the recommended differential pressure is sufficient. In order to achieve a noiseless function we recommend in smaller systems to apply automatic bypass valves or automatic balancing valves. If pump differential pressure exceeds the recommended max. valve differential pressure it is recommended that an automatic balancing valve type ASV-P/PV is added to the system.

Accessories and spare parts for integrated valve 013G1382

	Code no.
Gland seal	013G0290
Protection cap (red)	013G0951

Pre-setting values, flow director + integrated valve

Flow director + integrated valve	Presetting								
	k _v -value ²⁾								k _{vs}
	1	2	3	4	5	6	7	N	
Flow director + RA 013G1382	0.14	0.18	0.26	0.32	0.45	0.55	0.69	0.84	1.18

²⁾ k_v-values indicate the flow volume (Q) in m³/h at a pressure loss (Δp) across the valve of 1 bar. $k_v = Q / \sqrt{\Delta p}$. At setting N, the k_v-value in accordance with EN 215 can be stated as Xp = 2 K. At lower preset values, Xp will be reduced until approximately Xp 0.5 at presetting 1. The table shows the average measured values for integrated valves with radiator. The k_{vs}-values indicate the valve capacity, when the valve is fully open. If a remote temperature adjuster is used, the P-band is increased by a factor of 1.1. If a liquid filled radiator thermostat is used, the P-band is increased by a factor of 1.6.

Design and dimensions

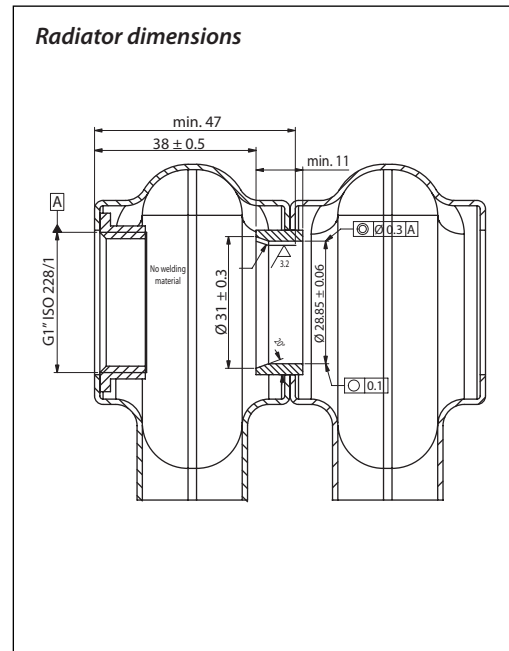
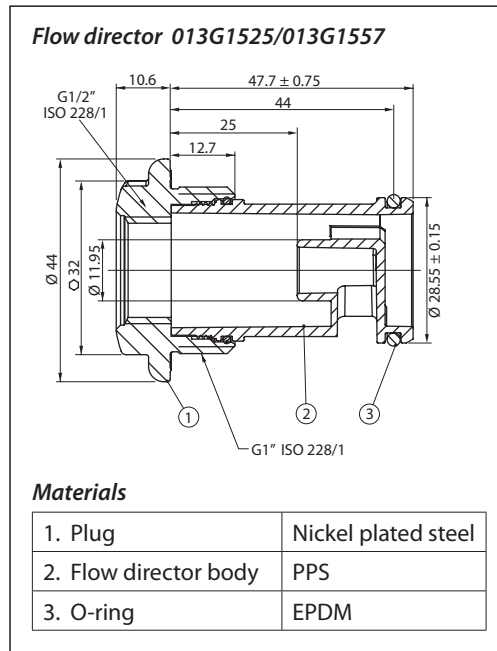

Capacities

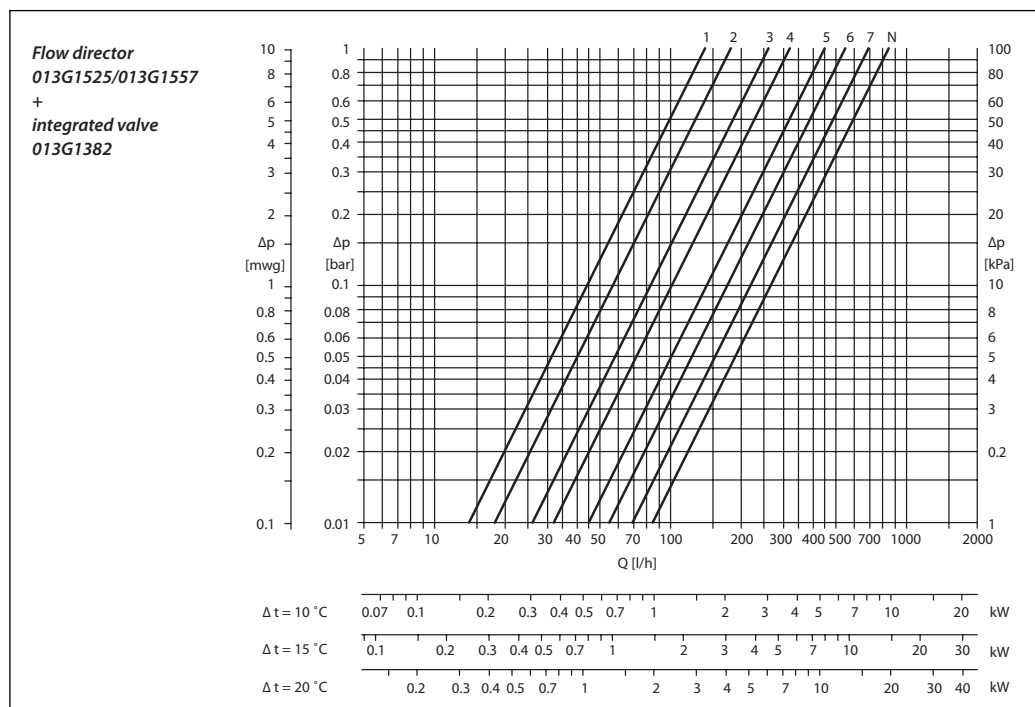

Danfoss can accept no responsibility for possible errors in catalogues, brochures and other printed material. Danfoss reserves the right to alter its products without notice. This also applies to products already on order provided that such alterations can be made without subsequential changes being necessary in specifications already agreed. All trademarks in this material are property of the respective companies. Danfoss and the Danfoss logotype are trademarks of Danfoss A/S. All rights reserved.